

Wall System E Series Technical Installation Manual

Issue Date: July 26, 2016

A note to readers utilizing this updated document:

This version of the HP+ Wall System Technical Installation Manual has significant updates to expand methods of installation and clarify previous installation requirements. While all modifications add clarity to the overall document, BASF has highlighted a few major changes for reference below:

1. The handling and storage document for Neopor® has an updated name – “Neopor Handling Instructions.”
2. Requirements for Premanufactured HP+ Panels are added in Handling and Storage, and WALLTITE® HP+ Spray Foam Installation. Additionally, DrJ Engineer’s Technical Evaluation Report includes added information regarding site modification of panels for structural connectors or Mechanical Electrical and Plumbing additions.
3. The use and requirements for “Temporary” bracing were restructured and clarified. Bracing is now called out as “Temporary perpendicular bracing” OR “Pre-WALLTITE HP+ in-plane bracing.” The new content explains the multiple options available and their associated requirements.
4. The fastening requirement for Neopor panels was modified to 12”o.c. at panel edges and 16”o.c. in the field. **This change ONLY occurs in the E-series document.**
5. Damage repair for “Small damage repair against stud or plate” also shown in “Section B” was clarified to allow any two-component closed cell spray foam application, rather than exclusively requiring WALLTITE HP+. BASF wanted to give more flexibility to the builder for small modifications made after WALLTITE HP+ installation. This change no longer requires a full rig on site to make minor repairs.

Wall System E Series Technical Installation Manual

Issue Date: July 26, 2016

Only the most recent published installation manual should be used. The most recent document is available at: <http://www.construction.basf.us/resources/technical-resources>

CONTENTS:

Handling and Storage	2	Water Resistive Barrier (WRB) Installation	5
Framing and Bracing Requirements	2	Vapor Barrier Considerations	5
Neopor® GPS Rigid Foam Insulation Board (sheathing)	3	Thermal and Ignition Barrier Requirements	5
WALLTITE® HP+ Spray Foam Installation	4	Damage Repair Recommendations	5

General Information:

Code Requirements:

This manual is intended to provide general information to the builder, designer, and end user. The following guidelines will help you properly install the HP+ E Series wall system. Failure to install and finish this product in accordance with these guidelines and applicable building codes may lead to personal injury, affect system performance, and violate local building codes. These guidelines will not cover every installation as they are general in nature. Proper installation is defined as the most restrictive requirement specified by BASF Corporation, DrJ Engineering Technical Evaluation Report (TER) 1403-01 or 1403-02, manufacturer's installation guidelines, local building code, engineer or architect of record, or other authority having jurisdiction. The builder and / or installer acknowledges that it is solely your obligation to comply with safety requirements and code compliance.

Neopor GPS Rigid Foam Insulation Board:

NEOPOR ICC ESR- 3463, Neopor Handling Instructions, and the manufacturer's installation manual must be followed throughout installation.

WALLTITE HP+ Building Envelope Insulation (closed cell spray foam insulation):

WALLTITE HP+ ICC ESR-2642 must be followed throughout installation by a BASF WALLTITE HP+ Certified Installer that has completed the BASF Quality Assurance and Training Program (QATP).

What is the HP+ Wall System?

HP+ Wall System E Series is a durable, structural assembly that meets or exceeds codes while using less wood than traditional construction, resulting in exceptional energy and cost efficiency.

The wall assembly features the following:

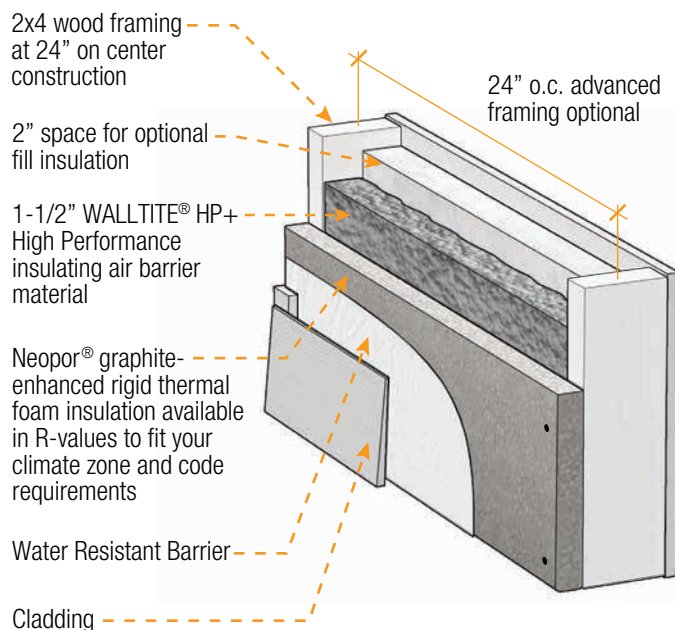

TIP!

DrJ Engineering TERs may be found at www.drjcertification.org/code-compliance. WALLTITE HP+ and Neopor ESRs may be found at www.spf.basf.com and www.neopor-insulation.com respectively.

Handling and Storage:

Neopor® GPS Rigid Foam Insulation Board:

- Storage and handling to follow “Neopor Handling Instructions” and manufacturer’s instructions.
- Must be protected at all times from reflected sunlight, prolonged solar exposure, and excessive moisture exposure.
- Can remain exposed after installation for up to 90 days.
- Must be protected during storage and transportation with corrugated cardboard and/ or white opaque film only. Corners and edges must be protected to limit damage to sheathing.
- Must be fork-lifted or carried off the truck not “dumped” off the back.

TIP!

The “Neopor Handling Instructions” document is available at www.Neopor-insulation.com.

WALLTITE® HP+ Building Envelope Insulation:

- Component storage to follow WALLTITE HP+ ICC ESR-2642.

- Shelf life of WALLTITE HP+ is approximately 6 months when stored in original, unopened containers at 50-80 degrees F.
- Components must be stored in a covered, secure location and never in direct sunlight.

Premanufactured HP+ Panels:

- To minimize damage to Neopor sheathing and discoloration of WALLTITE HP+ due to UV exposure, stack panels Neopor to Neopor and stud to stud.
- Allow time for cooling of panels prior to stacking.
- Discoloration due to UV exposure is cosmetic only and does not affect structural integrity or insulation values.
- Protect finished panels from weather and UV exposure using an acceptable method outlined in “Neopor Handling Instructions” or manufacturer’s instructions.
- During handling, avoid dragging and dropping panels to avoid panel damage.

Framing and Bracing Requirements:

Confirm the installation crew is familiar with the provisions of the construction documents, this installation manual, site specific conditions and issues, and OSHA jobsite lifting and fall protection requirements.

Advanced Framing Considerations:

Advanced Framing (also known as Optimum Value Engineering) may be incorporated with this wall system by the Design Professional. Contact your Design Professional to coordinate which advanced framing options, if any, were designed into the wall system.

Additional studs or blocking may be required by the cladding manufacturer, or for window and door frame bearing. Follow manufacturer’s installation instructions or contact the Center for Building Excellence to evaluate discrepancies.

Temporary perpendicular bracing:

Means and methods for construction of temporary bracing perpendicular to exterior walls are the responsibility of the building contractor. For guidance in temporary perpendicular bracing, see SBCA’s *Guide for Handling, Installing & Temporary Bracing of Wall Panels*.

Pre-WALLTITE HP+ in-plane bracing:

In plane bracing, as described below, must remain in place until the complete HP+ Wall E Series–system (or Walltite HP+ closed cell spray foam) is installed.

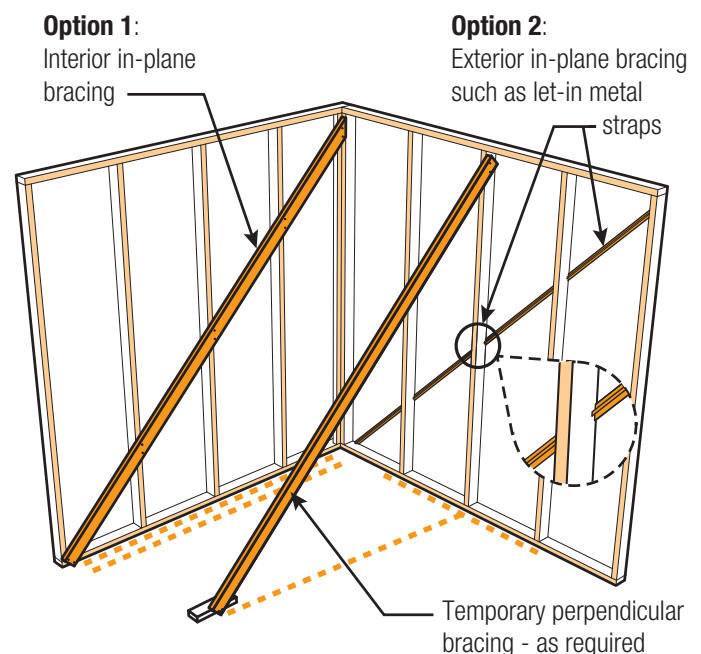

TIP!

Pre-WALLTITE HP+ in-plane bracing must remain installed until WALLTITE HP+ is installed to complete the structural system. The Neopor sheathing alone is not an approved bracing method.

Panels built off-site may or may not be fully braced. Verify panel installation requirements with Design Professional of record or panel manufacturer.

Pre-WALLTITE HP+ in-plane bracing can follow any code-approved wall bracing method. The following description highlights two common methods that cover most installations. The installer may use either of these options OR another code approved bracing method to meet bracing needs.

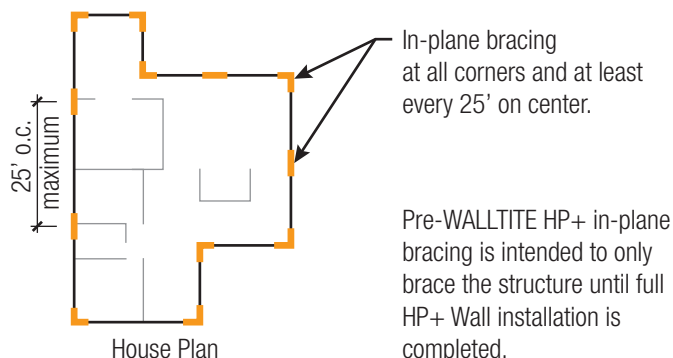

Interior in-plane bracing (Option 1):

- Diagonal bracing on the interior face of the framed wall must be spaced a maximum of 25' o.c. along the length of the wall line and at each corner.
- Face nail each brace to the top and bottom plates and each backing stud to obtain a minimum 1" nail penetration into the stud.

Neopor® GPS Rigid Foam Insulation Board (sheathing):

All items below apply regardless of wall construction method (e.g. tilt up, site built, or panelized).

TIP! Sheathing must be installed vertically with the long dimension of the panels parallel to the stud behind and all panel edges supported by framing or blocking. See TER section 6.2.2.

Fastening requirements:

TIP! Multiple fastening methods are allowed with the HP+ E Series. Refer to TER section 6.2 and the Construction Documents to determine the minimum fastening requirements for your project.

One approved method is galvanized roofing / siding nails. When using galvanized nails, they must have a minimum of 0.113" shank diameter and a 3/8" diameter head.

- Fasteners must be of sufficient length to penetrate the framing a minimum of 3/4" and must be installed with the head flush to the surface of the sheathing
- Fasteners must be spaced a maximum 12" o.c. at panel edges and 16" o.c. in the field

Exterior in-plane bracing (Option 2):

- Let-in diagonal bracing utilized on the exterior face of the framing must be spaced a maximum of 25' o.c. along the length of the wall line and at each corner.
- Ensure bracing is set at a 45° angle along the plane of the wall and extends from the top of the wall, to the bottom plate along the floor line.
- Fastening frequency and fastener penetration must comply with code bracing requirements for each bracing method. Where proprietary bracing is used, consult the manufacturer's installation instructions.

Permanent Bracing Requirements:

Bracing requirements must follow the Wall Bracing Design drawing provided in the plan set and the TER to which it references.

TIP! The fastener type and the panel edge and field fastening pattern are listed in the Wall Bracing Design drawing.

Uplift Strapping:

Install any necessary mechanical strapping directly to framing. Any metal straps, ties, or other connectors designed to resist uplift or shear loads must be installed prior to Neopor installation. The requirement for mechanical uplift connections must be determined by the designer of record, local building codes, or authority having jurisdiction.

Installation Tolerances:

Refer to the TER for installation tolerances acceptable for finished framing installation.

- Neopor panel edges have a fastening tolerance as described in the graphic below:

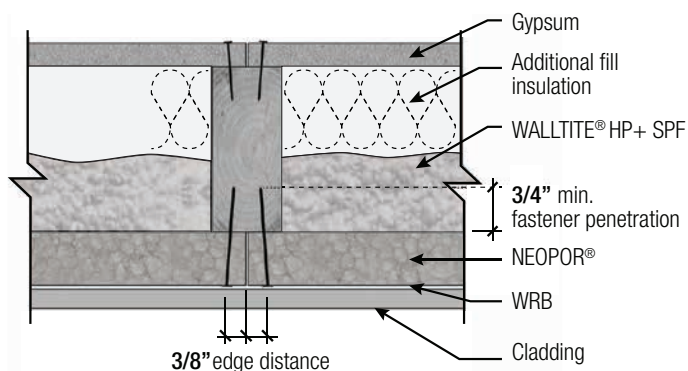

TIP! Maintain a tight connection to studs to prevent spray foam from expanding in any space left between the Neopor and the stud, resulting in an uneven surface for the cladding.

Coordinate cladding attachment with manufacturer's requirements for installation over foam sheathing.

Clearance and flashing requirements:

- Maintain a minimum 6" clearance between ground and sheathing.
- We recommend the use of Z-flashing installed directly to the sill plate before sheathing is applied. This is for pest protection, any remaining moisture wicking, and provides a finish edge.

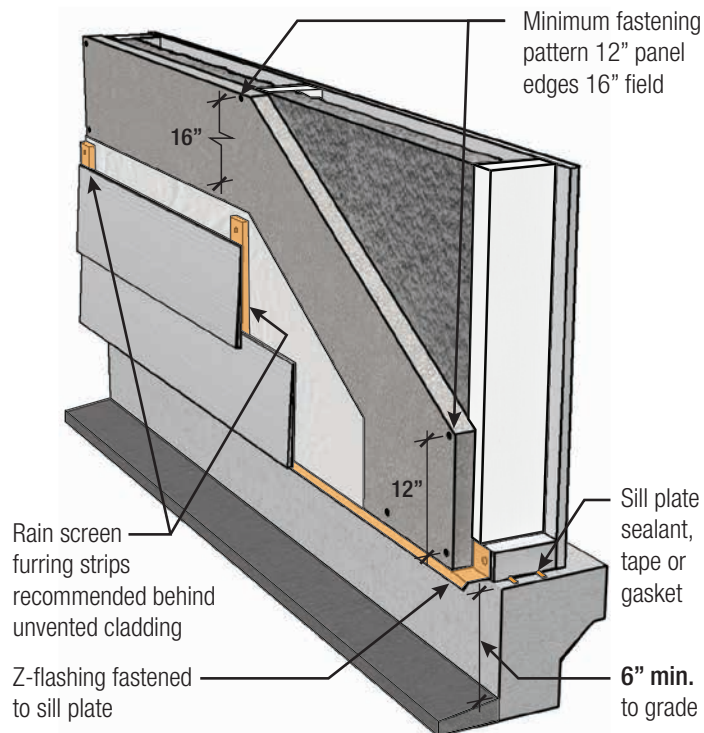
**WALLTITE® HP+ Spray Foam Installation:**

For site-built projects, installation must only start after all exterior walls on all floors have been framed and braced, and all exterior Neopor® sheathing has been attached.

Only a BASF WALLTITE HP+ Certified Installer that has completed the BASF Quality Assurance and Training Program (QATP) can install WALLTITE HP+.

Once all roof and floor framing is fully installed, temporary perpendicular bracing may be removed (see Pre-WALLTITE HP+ in-plane bracing).

During WALLTITE HP+ installation, in-plane interior bracing may only be removed in a maximum of 25' linear sections once all roof, floor diaphragms, and interior walls are framed. Each 25' section must receive full spray application of 1.5" before the next 25' section of temporary interior bracing is removed.

Excerpts from the WALLTITE HP+ ESR and the TER are reproduced below for quick reference:

- WALLTITE HP+ sets almost immediately. Ensure wall is square and true prior to spray foam application.
- Ensure the interior face of the Neopor sheathing is unfaced with any plastic, foil, or other film before application.
- First pass may not exceed ½ inch on Neopor substrate. Subsequent passes must allow minimum 20 minute dwell time. Dwell time can be adjusted based on QATP requirements.

- All personnel entering the work area must wear appropriate personal protective equipment according to the WALLTITE HP+ ESR, the "Guidance on Best Practices for the Installation of Spray Polyurethane Foam" by the Spray Foam Coalition, and the QATP.
- Safety signage must be posted at all entrances.
- A Daily Work Record (DWR) sheet is required for each project. A copy of the DWR must be retained by the contractor as outlined in the QATP.

For Premanufactured HP+ Panels:

- Spray Foam application area must be isolated and ventilated per guidelines set forth in the WALLTITE HP+ ESR.
- When applying WALLTITE HP+ to panels in the panel plant, install horizontal ladder blocking in the end stud cavity of each panel at 30" - 36" o.c. vertically to brace end stud against bowing. Ladder blocking should be installed with the wide face either against Neopor or flush with the interior stud face to allow for WALLTITE HP+ coverage over or behind the blocking to prevent thermal bridging.

TIP! Reference provisions in TER section 5.1.4. for approved means and methods to accommodate hold-downs or other structural connectors added onsite.

Water Resistive Barrier (WRB) Installation:

A water – resistive barrier is required on top of Neopor sheathing in accordance with local building code requirements. The WRB must be installed with penetration and joint flashing in accordance with local building code requirements.

We recommend a rain screen assembly behind unvented cladding to ensure proper WRB drainage and promote drying of the wall assembly to the outside.

Vapor Barrier Considerations:

WALLTITE® HP+ is a Class II Vapor Retarder when installed at 1.5". Please see WALLTITE HP+ ICC ESR-2642 to determine the vapor transmission class at other thicknesses.

Additional Vapor Retarders **MUST NOT** be installed on either the exterior or interior of the wall when WALLTITE HP+ depth exceeds 1.5". Ensure interior and exterior material finishes are vapor permeable or ventilated.

Thermal and Ignition Barrier Requirements:

All exposed WALLTITE HP+ and Neopor® must be separated from the interior of the building by a minimum 15-minute thermal barrier.

There must be a minimum 2" clearance between WALLTITE HP+ and all combustion appliances and components such as fireplaces and flues or as required by the appliance manufacturer, whichever is more stringent.¹

There must be a minimum 3" clearance between WALLTITE HP+ and all recessed can lights – even IC rated fixtures.¹

Damage Repair Recommendations:

Definitions of repair size:

- **Small damage repair:** an area smaller than a 10"x10" square, located more than 18" from the top and bottom plates, and more than 1" away from the studs (Section A). An example that fits into this definition is moving a side-wall vent.
- **Small damage repair against stud or plate:** an area smaller than 10" x 10" located within 18" from the top and bottom plates, and less than 1" away from the studs (Section B).
- **Large damage repair:** an area outside of the limitations of small damage repair and small against stud damage repair (Section C).

TIP! One component and two-component foams used for WALLTITE HP+ repair must be polyurethane based.

Sealants and caulking used to repair WALLTITE HP+ and Neopor foam must be polyurethane based. BASF manufactures MasterSeal® NP 1 one-component elastomeric polyurethane sealant, which complies with these requirements

Neopor sheathing damage only:

- **Small damage repair** – Damaged material can be removed and/ or replaced with the same size plug of OSB laminated Neopor material. The repair piece must be adhered, taped, or mechanically fastened to avoid any change in sheathing plane. Do not tape the interior face of the sheathing which would prevent full adherence of the WALLTITE HP+ spray foam.
- **Small damage repair against stud or plate** – Damaged material can be removed and / or replaced with the same size plug of OSB laminated Neopor material in the same method as in small damage repair.
- **Large damage repair** – Requires full sheet replacement.

WALLTITE HP+ damage only:

- **Small damage repair** – Repair with a single-component spray or can polyurethane foam.
- **Small damage repair against stud or plate** – Repair with a two-component closed cell spray foam application.
- **Large damage repair** – Repair with a two-component closed cell spray foam application using WALLTITE HP+.

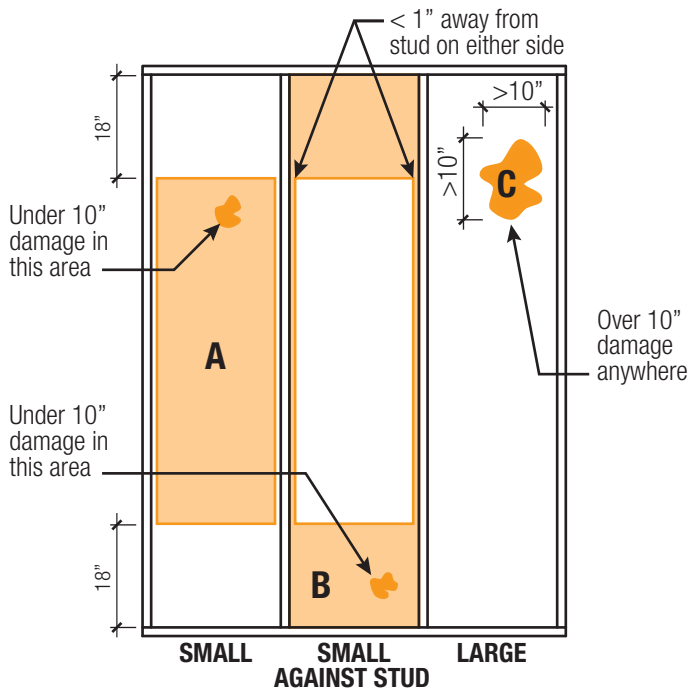

HP+ Wall System damage:

- **Small damage repair** – Repair OSB laminated Neopor with same size plug of same material. The repair piece must be adhered, taped, or mechanically fastened to avoid any change in sheathing plane. Seal edges with single-component spray OR can polyurethane foam OR sealant. Fill cavity insulation void with an equivalent R-value substitute.
- **Small damage repair against stud or plate** – Repair with a two-component closed cell spray foam application.
- **Large damage repair** – The entire framing bay(s) damaged must be fully repaired following the original Construction Document requirements, the TER and this Installation Manual.

¹ As outlined in the Seal & Insulate with ENERGY STAR supplement to the ESR-2642 and local code requirements. (2015 IRC: R1001.11 Fireplace Clearance; R1003.18 Chimney Clearance; R302.14 Combustible Insulation Clearance)

ENERGY STAR is a registered trademark of the Environmental Protection Agency.

MasterSeal is a registered trademark of BASF Group, ENERSHIELD and WALLTITE are registered trademarks of BASF Corporation, HP+ Wall System is a registered trademark of BASF (patents pending). Neopor is a registered trademark of BASF SE.

©2016 BASF Corporation – July 26, 2016